

Rothe Erde Großwälzlager. Bordkran.

**Large Diameter
Antifriction Bearings.**

Deck Crane.

**Couronnes
d'orientation.**

Grue de Bord.

**Cuscinetti volventi
di grande diametro.**

Gru di Bordo.

Anfrage-Daten.

Questionnaire.

Questionario.

KD 104

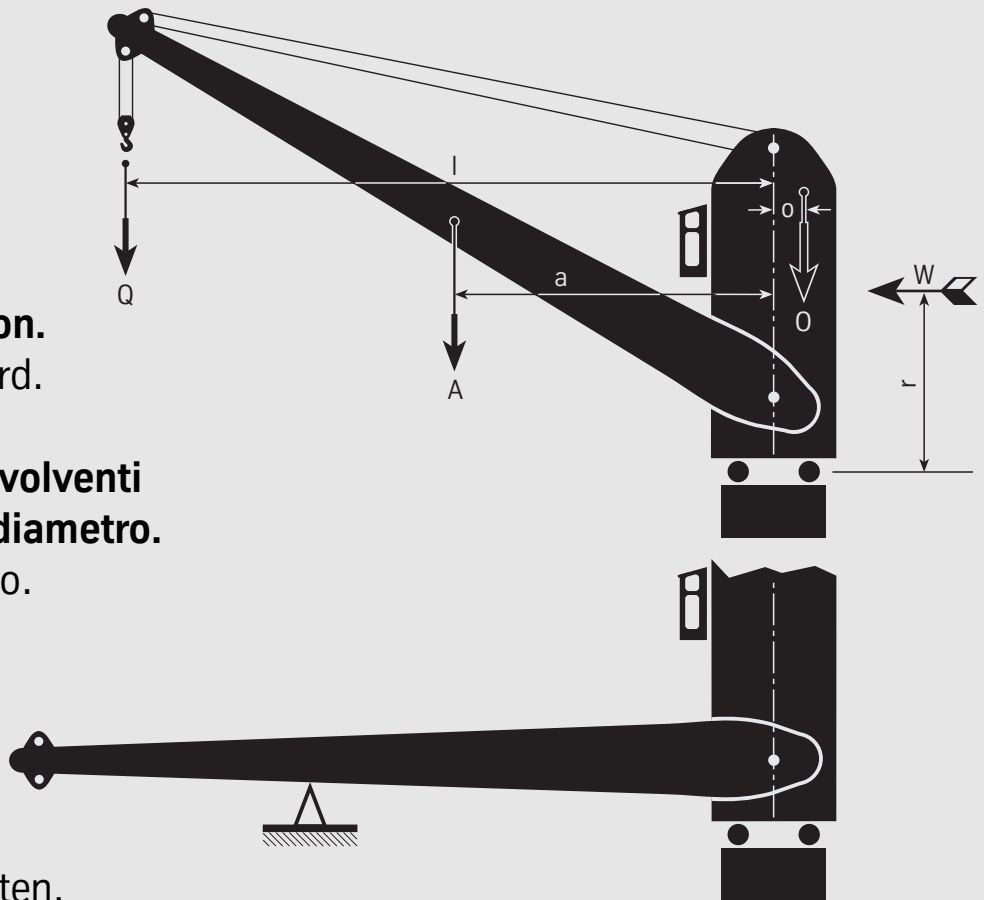

Bordkran

Belastungsart:
Stückgut-Betrieb _____

Belastungsart:
Greifer-Betrieb _____

_____ DIN FEM

Hubklasse _____

Beanspruchungsgruppe _____

Kräfte Loads Forces Forze	in/en kN
_____	_____
Q bei/at l_{max}	= _____
Q bei/at l_{min}	= _____
A	= _____
O	= _____
W	= _____

Deck Crane

Load type:
cargo operation _____

Load type:
grabber operation _____

_____ DIN FEM

Lifting class _____

Duty group _____

Drehmoment am Zahnkranz Torque at the gear ring Couple de rotation sur bague dentée Coppia di rotazione sulla dentatura	in/en kNm
_____	_____
M_d normal/normale	= _____
M_d max	= _____

Grue de bord

Mode d'utilisation:
service à crochet _____

Type de grue:
service à benne _____

_____ DIN FEM

Classe de levage _____

Groupe de sollicitation _____

Abstände Distances Distances Distanze	in/en m
_____	_____
$l_{max 1}$ ohne Krängung without heeling sans gîte	= _____
$a_{max 1}$ senza sbandamento	_____
$l_{max 2}$ bei Krängung with heeling avec gîte	= _____
$a_{max 2}$ con sbandamento	_____
o	= _____
r	= _____

Gru di bordo

Tipo di esercizio:
a gancio _____

Tipo di esercizio:
a benna _____

_____ DIN FEM

Classe di sollevamento _____

Gruppo di utilizzazione _____

Krängungs-Winkel Heeling angle Angle de gîte Angolo di sbandamento	γ	=	$^{\circ}$
_____	_____	_____	_____

1.	Normalbelastung einschließlich Wind Efforts normaux y compris vent	Normal load incl. wind Carico normale compreso vento	bei größter Ausladung ohne Krängung at max. working radius without heeling pour charge maxi, sans gîte a sbraccio mass. senza sbandamento	bei größter Ausladung einschl. Krängung at max. working radius with heeling pour charge maxi. y compris gîte a sbraccio mass. compreso sbandamento
1.1	Axialkraft Charge axiale	Axial load Forza assiale	$F_{a1} = Q + A + O$	$F_{a2} = Q + A + O$
1.2	Radialkraft Charge radiale	Radial load Forza radiale	$F_r = W + Z^*$	$F_r = W + Z^*$
1.3	Resultierendes Moment Moment résultant	Resulting moment Momento risultante	$M_1 = Q \cdot l_{\max 1} + A \cdot a_{\max} + W \cdot r - O \cdot o$	$M_2 = Q \cdot l_{\max 2} + A \cdot a_{\max} + W \cdot r - O \cdot o$
<p>*Z = Resultierende Umfangskraft aus Drehmoment am Zahnkranz Resulting tangential force from torque at gear ring Effort tangentiel admissible résultant du couple de rotation sur bague dentée Forza periferica ammissibile della coppia di rotazione sulla dentatura</p>				

2.	Belastung einschl. 25 % Hublasterhöhung ohne Wind Charges y compris 25 % de surcharge sans vent	Load incl. 25 % test load without wind Carico compreso 25 % di sovraccarico senza vento		
2.1	Axialkraft Charge axiale	Axial load Forza assiale	$F_{a1} = 1,25 \cdot Q + A + O$	
2.2	Resultierendes Moment Moment résultant	Resulting moment Momento risultante	$M_1 = 1,25 \cdot Q \cdot l_{\max 1} + A \cdot a_{\max} - O \cdot o$	

3.	Fahrt des Schiffes Ausleger abgelegt und verzurt Navire en mouvement, flèche déposée et amarrée	Ship sailing with boom stowed Nave in crociera, braccio appoggiato e arriato		
3.1	Axialkraft Charge axiale	Axial load Forza assiale	$F_a = 0$	
3.2	Resultierendes Moment Moment résultant	Resulting moment Momento risultante	$M = 0 \cdot o$	

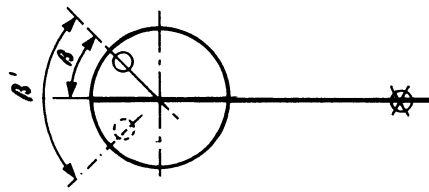
		normal	normale	maximal	massimo
4. Drehzahl Number of revolutions (per minute)	Vitesse de rotation Numero di giri				min. ⁻¹
4.1 Schwenkbewegungen Slewing	Oscillations Movimenti oscillatori				°
4.2 M _d an der Ritzelwelle Pinion torque	Couple à l'arbre du pignon Coppia di comando all'albero del pignone M _d				kNm
4.3 Anzahl der Ritzel und Position zum Ausleger Number of pinion and position to boom	Nombre de pignons et position par rapport à la flèche Numero pignoni e posizione verso il braccio				
5. Gewünschter Ø außen/innen Required dia., outer/inner	Ø intérieur ou extérieur souhaité Diametro richiesto, esterno/interno		mm/		mm
6. Verzahnung (außen/innen/ohne) Gear (external/internal/without)	Denture (extérieure/intérieure/sans) Dentatura (esterna/interna/senza)				
6.1 Zahnbreite Face width	Largeur de la dent Larghezza dentatura				mm
6.2 Verzahnung am feststehenden oder drehenden Konstruktionsteil? Is gear on the fixed or the rotating part of machine?	Denture sur bague fixe ou mobile? La dentatura fa parte della parte mobile o fissa dell'impianto?				
7. Ritzeldaten Pinion data	Caractéristiques pignon Dati del pignone di comando				
7.1 Modul Module	Module Modulo				
7.2 Zähnezahl Number of teeth	Nombre de dents Numero dei denti				
7.3 Profilverschiebung x · m Profile correction x · m	Déport x · m Correzione x · m				
7.4 Kopfkürzung Addendum modification	Troncature Troncatura di testa del dente				
8. Für die Ausarbeitung wirtschaftlicher Vor- schläge bitten wir, dieser Berechnungs- unterlage unbedingt Zeichnungen sowie Belastungsskizzen des Gerätes beizufügen. For the most economical proposal, please enclose drawings and load sketches of the unit.	Pour l'étude d'une proposition économique, nous vous prions de joindre notes de calcul, plans et schémas des charges. Per facilitare la stesura delle offerte allegare per quanto possibile disegni e schemi di carico alla presente richiesta.	Unterlagen, Documents, Documentazione:			
Firma / Company / Société / Ditta:		Sachbearbeiter / Projekt Engineer / Affaire suivie par / Elaborato da:			
Anschrift / Address / Adresse / Indirizzo:		Datum / Date / Date / Data:			



Rothe Erde GmbH
 Tremoniastraße 5-11
 D-44137 Dortmund
 Tel.: (02 31) 186-0
 Fax: (02 31) 186-25 00
 E-mail: rotheerde@thyssenkrupp.com
 Internet: www.rotheerde.com