

Rothe Erde Structural Elements for Aviation and Astronautics.

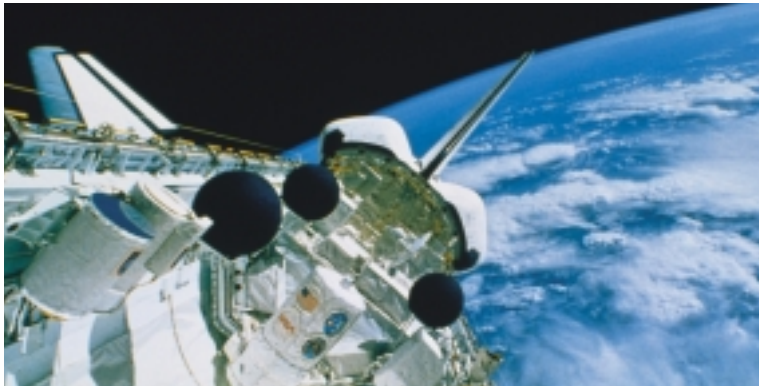

Rothe Erde Structural Elements for Aviation and Astronautics.

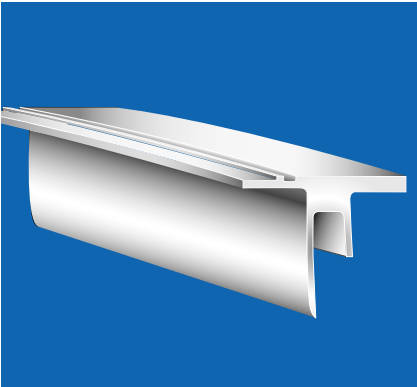

Structural element XMM.

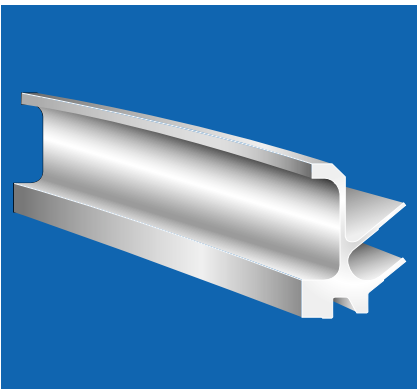

Structural element Titan 3.



Aluminium Forging.

Rothe Erde is the worldwide leading manufacturer of large-diameter antifriction bearings, including ball and roller bearing slewing rings, seamless-rolled steel and non-ferrous metal rings and well known manufacturer of turntables.

Rothe Erde rings are practice-proven machine construction components for many technological fields.

Rothe Erde seamless rolled rings are nowadays important structural elements for aviation and astronautics.

The Rothe Erde ring rolling mills count among the most modern production plants of its kind. They are equipped with CNC programmes which enable to warrant the reproducibility and quality of rolled rings which are particularly required for applications in space.



Ring Rolling Mill RAW 315.



Measurement of the Diameter.

Programme-controlled heat treatment processes ensure precise adherence to all specific time-temperature specifications for ferrous and nonferrous alloys with a high accuracy.

Rothe Erde processes all special alloys (titanium, copper and aluminium alloys) which are used for space applications.

The comprehensive Rothe Erde quality management system has been accredited and certified corresponding to the international quality standards DIN EN ISO 9001 and 9002.

Rothe Erde - the name for structural elements of highest quality and precision – accompanied by highly future-oriented perspectives.

Title pictures:

Right: ESA rocket Ariane 5 - 503 starting on October 21, 1998 from French Corou.

Application: Ariane 5.

Structural elements for payload carrier structures Speltra and Sylda.

Rothe Erde structural elements of aluminium have already contributed to the success of the ARIANE missions.

Rothe Erde rings have an extremely sophisticated cross section and diameters of up to 5.5 metres weighing only 23 to 57 kgs.

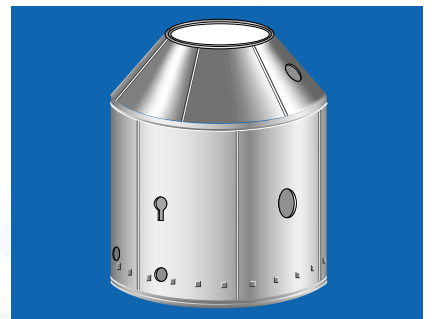
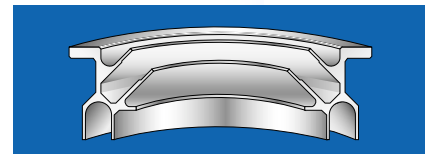
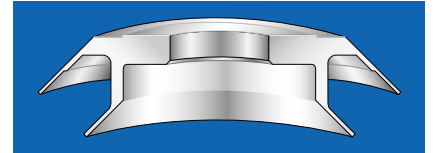

Structural elements for external payload carrier structure (Speltra).

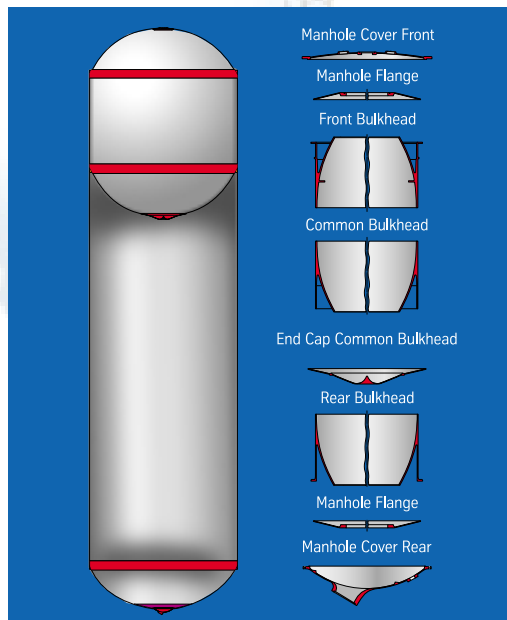

Tank bulkhead elements for the main propellant tanks of Ariane 5.



Cross section of Ariane 5 - 503.

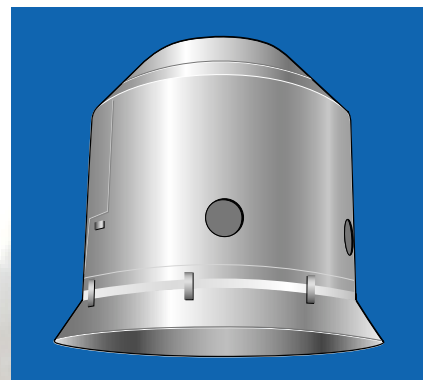
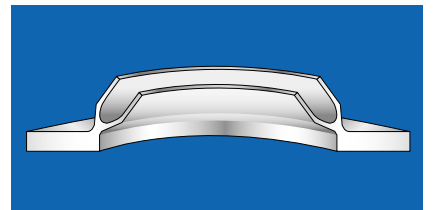
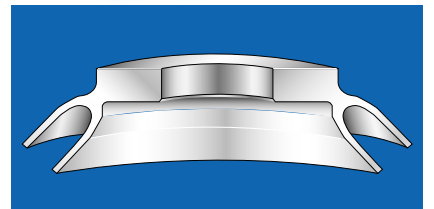

Structural elements for internal payload carrier structure (Sylda).

Application:
Scientific Satellite XMM (X-Ray Multi Mirror).
Structural elements for satellites.



Scientific Satellite XMM.

The X-ray telescope XMM ordered by ESA which has been designed and built under the supervision of Dornier Satellitensysteme GmbH has been successfully deployed during one of the first commercial flights of Ariane 5 on December 10, 1999. The scientific satellite, which has a weight of approx. 4 t and a length of approx. 11 metres, is able to collect blanketed radiation and to convert it into colour pictures. Thus, new possibilities are opening up for astronomers to come to a better understanding of the development from the big bang of the universe to the genesis of the planets.

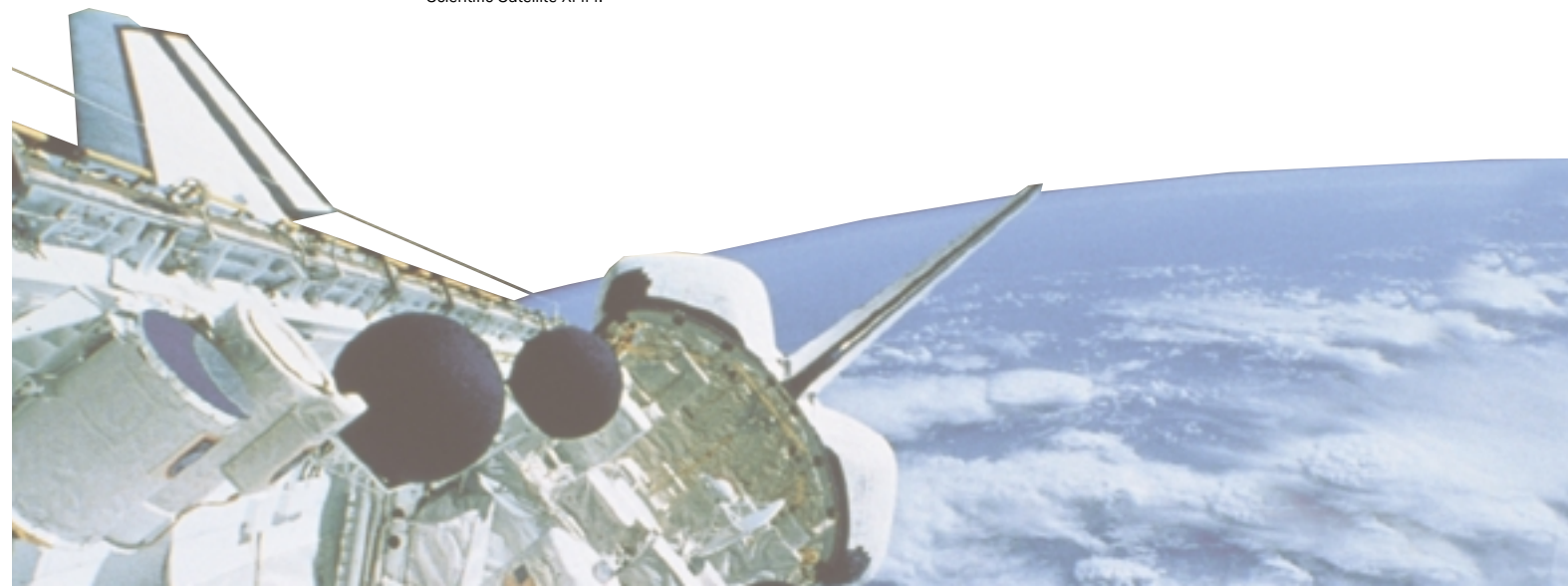

Application: Space Shuttle.

Wire-race bearing for satellite platform.

Fitness for space is demonstrated by a Rothe Erde wire-race bearing installed in a rotary platform on the NASA Space Shuttle for satellite deployment and retrieval.

This four-point aluminium wire-race bearing has a diameter of 1,830 mm, weighing 54 kgs.



Start.

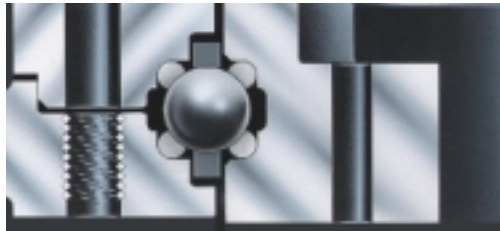

Four-point wire-race bearing.

Space Shuttle with open cargo hatches.



Head Office

Rothe Erde GmbH

Tremoniastrasse 5-11
D-44137 Dortmund
Phone: +49 (2 31) 186-0
Fax: +49 (2 31) 186-25 00
E-mail: rotheerde@thyssenkrupp.com
Internet: www.rotheerde.com

Offices in Germany

Berlin

Rothe Erde GmbH
Geschäftsstelle Berlin
Wittrasse 49
D-13509 Berlin
Phone: +49 (30) 43 09 18 68
Fax: +49 (30) 43 60 57 46
E-mail: gs-berlin.rotheerde@thyssenkrupp.com

North

Rothe Erde GmbH
Geschäftsstelle Nord
Am Pferdemarkt 31
D-30853 Langenhagen
Phone: +49 (5 11) 7 25 35 69-0
Fax: +49 (5 11) 7 25 35 69-9
E-mail: gs-nord.rotheerde@thyssenkrupp.com

South

Rothe Erde GmbH
Geschäftsstelle Süd
Am Ostkai 15
D-70327 Stuttgart
Phone: +49 (7 11) 3 27 79 19-0
Fax: +49 (7 11) 3 27 79 19-9
E-mail: gs-sued.rotheerde@thyssenkrupp.com

Subsidiaries

Brazil

Robrasa
Rolamentos Especiais
Rothe Erde Ltda.
Rua Lidia Blank, No. 48
BRA-CEP 09913-010, Diadema,
São Paulo
Phone: +55 (11) 40 55 84 00
Fax: +55 (11) 40 55 38 92
E-mail: robrasa@robrasa.ind.br
Internet: www.robrasa.ind.br

Great Britain

Roballo Engineering Co. Ltd.
Mill Hill
North West Industrial Estate
GB-Peterlee,
Co. Durham SR8 2HR
Phone: +44 (1 91) 5 18 56 00
Fax: +44 (1 91) 5 86 90 96
E-mail: info@roballo.co.uk
Internet: www.roballo.co.uk

Japan

Nippon Roballo Co., Ltd.
Fukide Bldg., 7th Floor
Toranomom 4-1-13
J-Minato-Ku/Tokyo
Zip: 1 05-00 01
Phone: +81 (3) 34 34 43 41
Fax: +81 (3) 34 34 43 40
E-mail: info@roballo.co.jp
Internet: www.roballo.co.jp

China

Xuzhou Rothe Erde Slewing
Bearing Co., Ltd.
Wanzhai, Northern Suburb,
VRC-Xuzhou 221007, Jiangsu
Phone: +86 (5 16) 87 66 18 12
Fax: +86 (5 16) 87 76 90 00
E-mail: xuzhou_rothe_erde@xreb.com
Internet: www.xreb.com

India

Rothe Erde GmbH
Liaison Office India
C-16, Bhagat Singh Marg
Off Prabhu Marg
Tilak Nagar
IND-Jaipur 302 004
Phone: +91 (1 41) 2 62 42 47
Fax: +91 (1 41) 2 62 42 30
E-mail: re_india@vsnl.net
Internet: www.rotheerdeindia.com

Spain

Roteisa
Rothe Erde Ibérica S.A.
Carretera Castellón, km. 7
Polígono Industrial „La Cartuja“
E-50720 La Cartuja Baja
(Zaragoza)
Phone: +34 (9 76) 50 04 80
Fax: +34 (9 76) 50 01 54
E-mail: roteisa@roteisa.es
Internet: www.roteisa.es

France

Roballo France S.à r.l.
30, Boulevard Bellerive
F-92566 Rueil Malmaison CEDEX
Phone: +33 (1) 41 39 00 90
Fax: +33 (1) 41 39 00 99
E-mail: contact@roballo-france.com

Italy

Rothe Erde-Metallurgica Rossi
S.p.A.
Viale Kennedy, 56
I-25010 Visano (Brescia)
Phone: +39 (0 30) 95 20-1
Fax: +39 (0 30) 95 20-3 00
E-mail: mri@rotheerde.it
Internet: www.rotheerde.it

USA

Rotek Incorporated
1400 South Chillicothe Rd.
P.O. Box 312
USA-Aurora, Ohio 44202
Phone: +1 (3 30) 5 62 40 00
Fax: +1 (3 30) 5 62 46 20
E-mail: sales@rotek-inc.com
Internet: www.rotek-inc.com

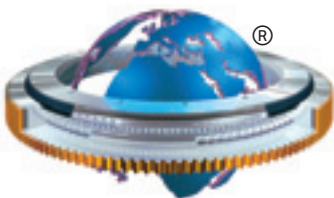

Rothe Erde